

Koploper in Zero Emissie MAN hTGX waterstoftruck





by ITOY

DE ROUTE NAAR ZERO EMISSIE

Stedelijke distributie

Nationaal en internationaal transport

Bouwvoertuigen

BATTERIJ ELEKTRISCH (BEV)

H₂ – BRANDSTOFCEL

H₂ – VERBRANDINGSMOTOR



MAN

M-AN 520

HIGHLIGHTS hTGX

-  520 PK / 2500 NM VERBRANDINGSMOTOR
-  ~ 600 KM RANGE
-  MINIMAAL 50 TON GCW
-  GECERTIFICEERD ALS ZEV (<1 G CO₂/KWH)
-  VRIJGEGEVEN VOOR ADR TRANSPORT
-  2.5 TON MEER LAADVERMOGEN T.O.V. BEV



NU BESTELBAAR, LEVERBAAR VANAF JULI 2025

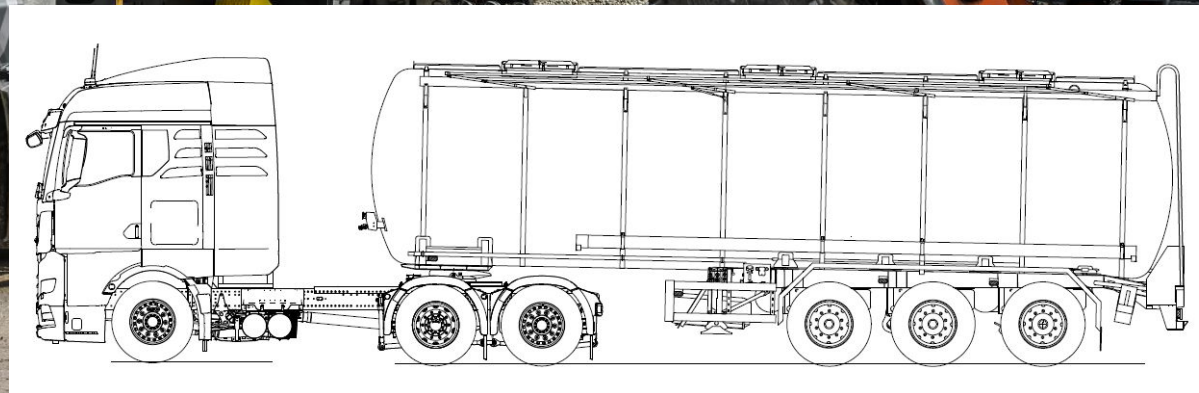
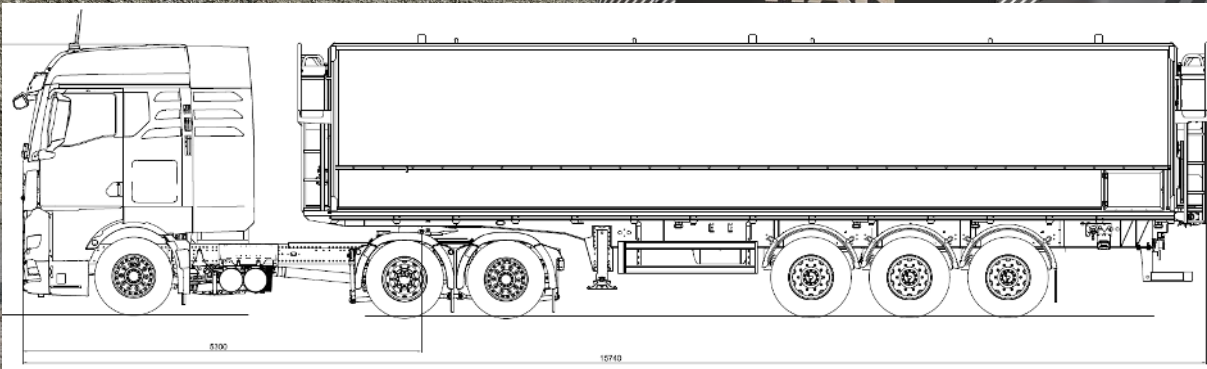
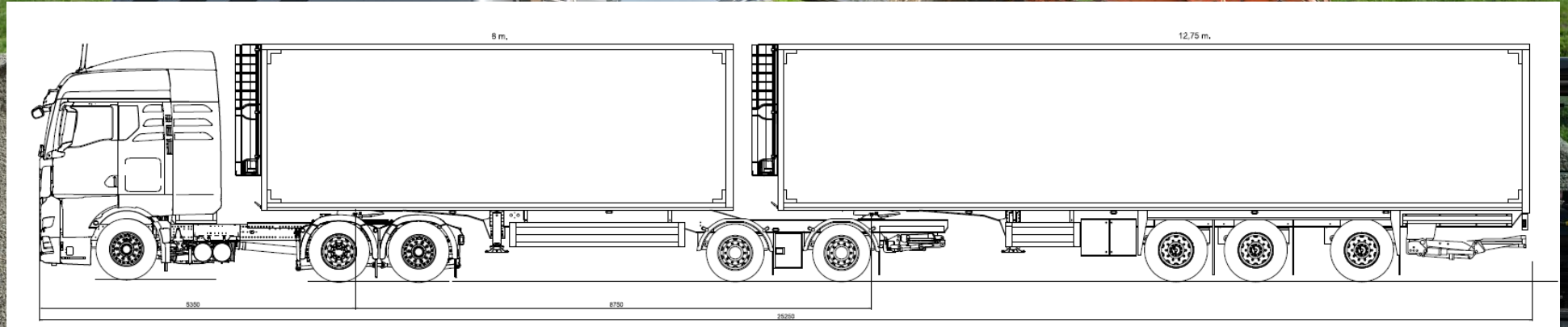
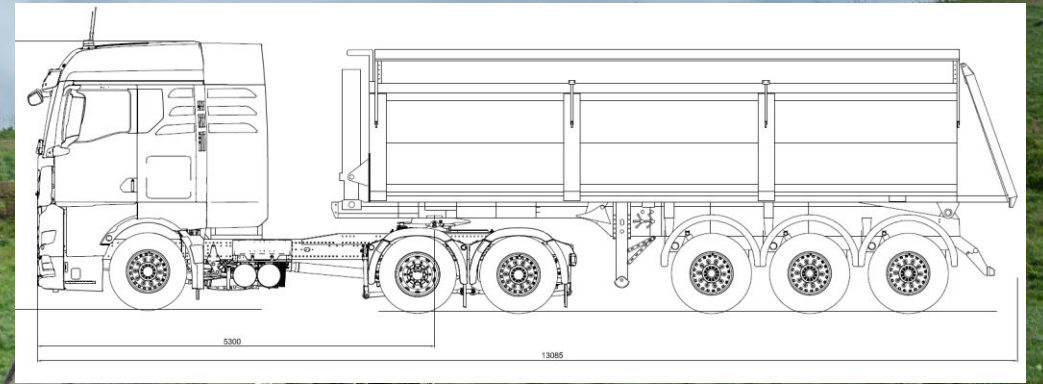
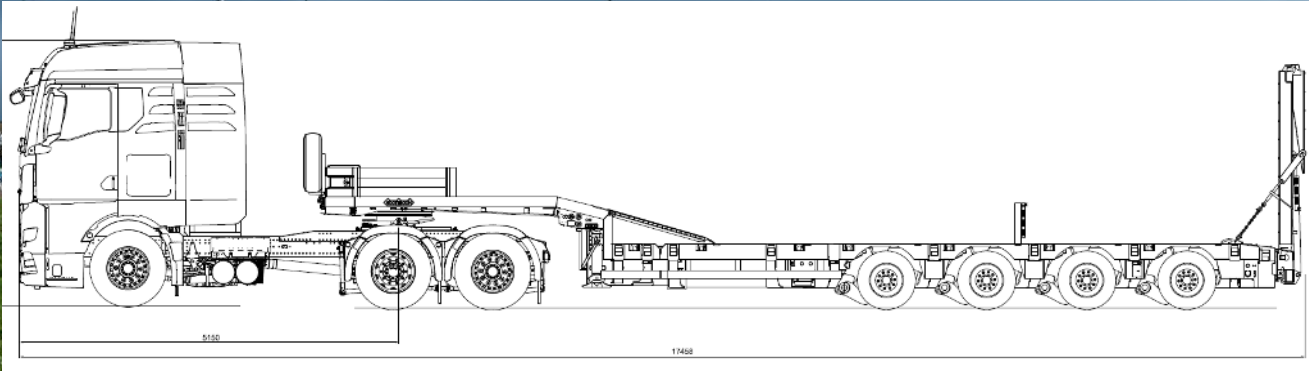

WANNEER IS WATERSTOF INTERESSANT?

ALS U NIET WILT OF KUNT INVESTEREN IN LAADINFRASTRUCTUUR



HOGE INZETBAARHEID

HOGE RANGE

HOGE GEWICHTEN

HOGE FLEXIBILITEIT

